

SEZIONE ANTA / DOOR SECTION

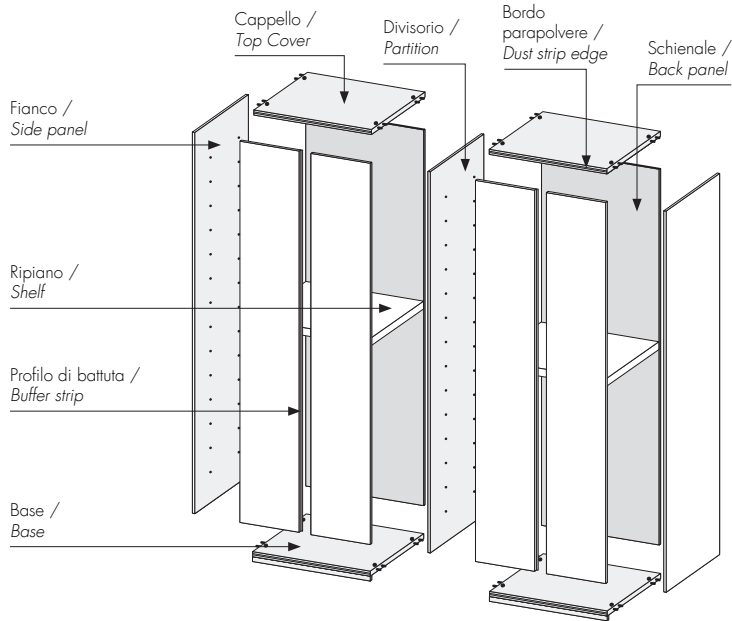

CARATTERISTICHE TECNICHE / TECHNICAL FEATURES



PER MANIGLIE DISPONIBILI
VEDERE SCHEDA MANIGLIE
FOR AVAIIABLE HANDLES PLEASE
SEE HANDLES DATA SHEET

DOTAZIONE INTERNA STANDARD PER VANO /
STANDARD INTERIOR FITTINGS PER MODULE

1 ripiano interno mobile e 2 tubi appendiabiti. /
1 movable internal shelf and 2 hanging rails.

ALTEZZE / HEIGHTS

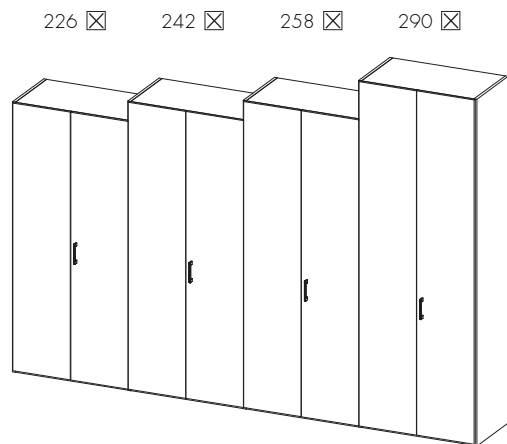

LARGHEZZE - PROFONDITA' / WIDTHS - DEPTHS

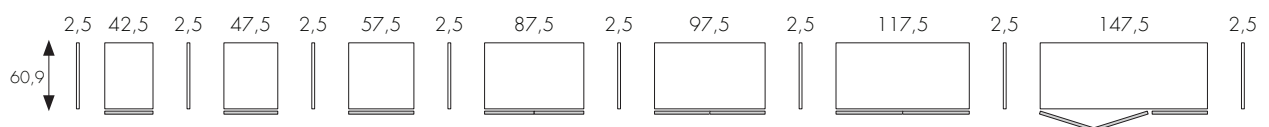

BATTENTE / HINGED	<input checked="" type="checkbox"/>	<input checked="" type="checkbox"/>	<input checked="" type="checkbox"/>	<input checked="" type="checkbox"/>	<input checked="" type="checkbox"/>	<input checked="" type="checkbox"/>	<input checked="" type="checkbox"/>	<input checked="" type="checkbox"/>	<input checked="" type="checkbox"/>	<input checked="" type="checkbox"/>	<input checked="" type="checkbox"/>	<input checked="" type="checkbox"/>	<input checked="" type="checkbox"/>	<input checked="" type="checkbox"/>
PIEGHEVOLE / FOLDING				<input checked="" type="checkbox"/>	<input checked="" type="checkbox"/>	<input checked="" type="checkbox"/>	<input checked="" type="checkbox"/>	<input checked="" type="checkbox"/>	<input checked="" type="checkbox"/>	<input checked="" type="checkbox"/>	<input checked="" type="checkbox"/>	<input checked="" type="checkbox"/>	<input checked="" type="checkbox"/>	<input checked="" type="checkbox"/>